

LTC 9210/01, LTC 9215/00 (S), LTC 9219/01, and LTC 9223/01 Indoor/ Outdoor Mounts

www.boschsecurity.com



BOSCH
Invented for life



- ▶ Feed-through Design for Cable Management
- ▶ Maximum Load: 9 kg (20 lb)
- ▶ 360° Rotation, 180° Tilt
- ▶ Versatile Design
- ▶ Adjustable Mount Heads

The LTC 9210/01, LTC 9215/00, LTC 9215/00S, LTC 9219/01 and the LTC 9223/01 feed-through mounts are indoor/outdoor mounting units designed for fixed camera, or camera housing installations with up to a 9 kg (20 lb) rated load. These models are made of lightweight aluminum and feature welded construction, providing an extremely rigid camera mount. In addition, the versatile swivel head rotates 360° and tilts 180° for maximum flexibility. The tubular feed-through design provides cable management from mounting head to mounting surface.

These mounts are compatible with the UHI Indoor Housing series and the UHO Outdoor Housing series. The LTC 9215/00S, has been designed specifically for the LTC 9480 Series housings, while the larger LTC 9215/00 and LTC 9219/01 can be used with the LTC 9480, HSG 9483, and the LTC 9488 Series camera housings. All mounts come fully assembled.

Installation/configuration notes

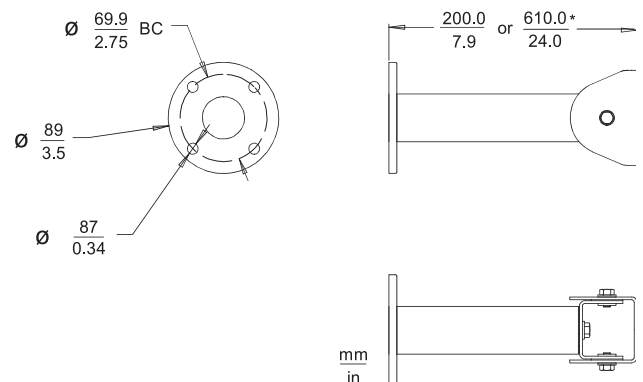

LTC 9210/01 and LTC 9223/01 Column Mount

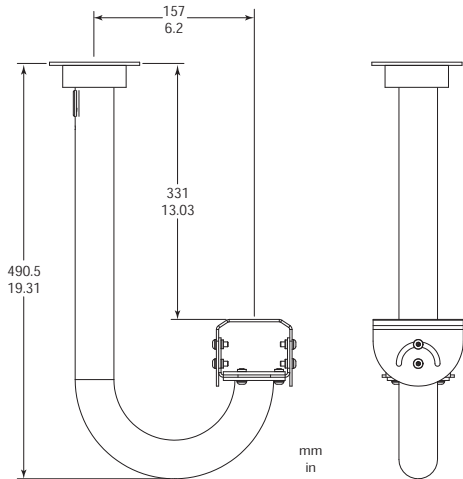

LTC 9219/01 Feed-through J-Mount

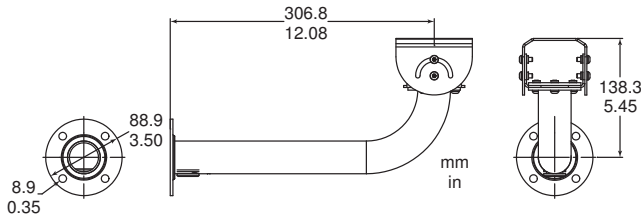
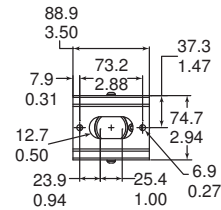

LTC 9215/00 Wall Bracket

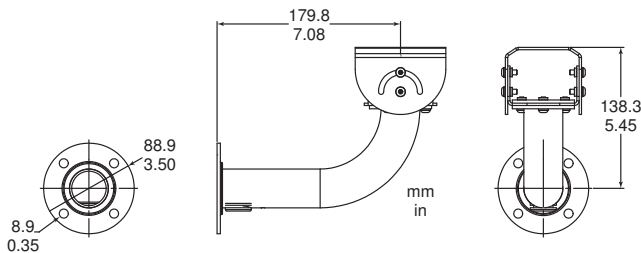
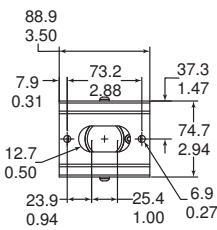

LTC 9215/00S Short Wall Bracket

Technical specifications

LTC 9210/01 20 mm (8 in) Indoor Outdoor

Column Mount	
Maximum Load	9 kg (20 lb)
Mounting Head	Adjustable 360° pan, 180° tilt
Finish	Light gray
Approx. Weight	0.3 kg (0.6 lb)

LTC 9215/00 30 mm (12 in) Indoor/Outdoor

Feed-through Wall Mount	
Maximum Load	9 kg (20 lb)
Mounting Head	Adjustable 360° pan, 180° tilt
Finish	Light gray
Approx. Weight	0.4 kg (0.9 lb)
Accessory for LTC 9215/00	LTC 9213/01 Pole Mount Adapter

LTC 9215/00S 18 cm (7 in) Indoor/Outdoor

Feed-through Wall Mount	
For use with LTC 9480 Series housings.	
Maximum Load	9 kg (20 lb)
Mounting Head	Adjustable 360° pan, 180° tilt
Finish	Light gray
Approx. Weight	0.3 kg (0.7 lb)
Accessory for LTC 9215/00S	LTC 9213/01 Pole Mount Adapter

LTC 9219/01 40 cm (15 in) Indoor/Outdoor

Feed-through Ceiling J-Mount	
Maximum Load	9 kg (20 lb)
Mounting Head	Adjustable 360° pan, 180° tilt
Finish	Light gray
Approx. Weight	0.55 kg (1.2 lb)

LTC 9223/01 610 mm (24 in) Indoor Outdoor

Column Mount	
Maximum Load	9 kg (20 lb)
Mounting Head	Adjustable 360° pan, 180° tilt
Finish	Light gray
Approx. Weight	0.544 kg (1.2 lb)



Notice

Mounts must be mounted as shown.

Ordering information

LTC 9210/01 Column Mount

for 8-inch, 9 kg (20 lb) max load, light gray finish
Order number **LTC 9210/01**

LTC 9215/00 Mount

Wall mount for LTC/HSG 948x, HSG9583 and UHI/UHO housings
Order number **LTC9215/00**

LTC 9215/00S Mount

Short wall mount for LTC/HSG 948x, HSG9583 and UHI/UHO housings
Order number **LTC9215/00S**

LTC 9219/01 Feed-through J-Mount

for 15-inch, 9 kg (20 lb) max load, for LTC 938x and LTC 948x series housings, light gray finish
Order number **LTC 9219/01**

LTC 9223/01 Column Mount

for 24-inch, 9 kg (20 lb) max load, light gray finish
Order number **LTC 9223/01**

Represented by:

Americas:

Bosch Security Systems, Inc.
130 Perinton Parkway
Fairport, New York, 14450, USA
Phone: +1 800 289 0096
Fax: +1 585 223 9180
security.sales@us.bosch.com
www.boschsecurity.us

Europe, Middle East, Africa:

Bosch Security Systems B.V.
P.O. Box 80002
5617 BA Eindhoven, The Netherlands
Phone: + 31 40 2577 284
Fax: +31 40 2577 330
emea.securitysystems@bosch.com
www.boschsecurity.com

Asia-Pacific:

Robert Bosch (SEA) Pte Ltd, Security Systems
11 Bishan Street 21
Singapore 573943
Phone: +65 6571 2808
Fax: +65 6571 2699
apr.securitysystems@bosch.com
www.boschsecurity.asia

China:

Bosch (Shanghai) Security Systems Ltd.
201 Building, No. 333 Fuquan Road
North IBP
Changning District, Shanghai
200335 China
Phone +86 21 22181111
Fax: +86 21 22182398
www.boschsecurity.com.cn

America Latina:

Robert Bosch Ltda Security Systems Division
Via Anhanguera, Km 98
CEP 13065-900
Campinas, Sao Paulo, Brazil
Phone: +55 19 2103 2860
Fax: +55 19 2103 2862
latam.boschsecurity@bosch.com
www.boschsecurity.com